

AMSTRAD

OWNER'S MANUAL

DMP-1

DOT MATRIX GRAPHIC PRINTER

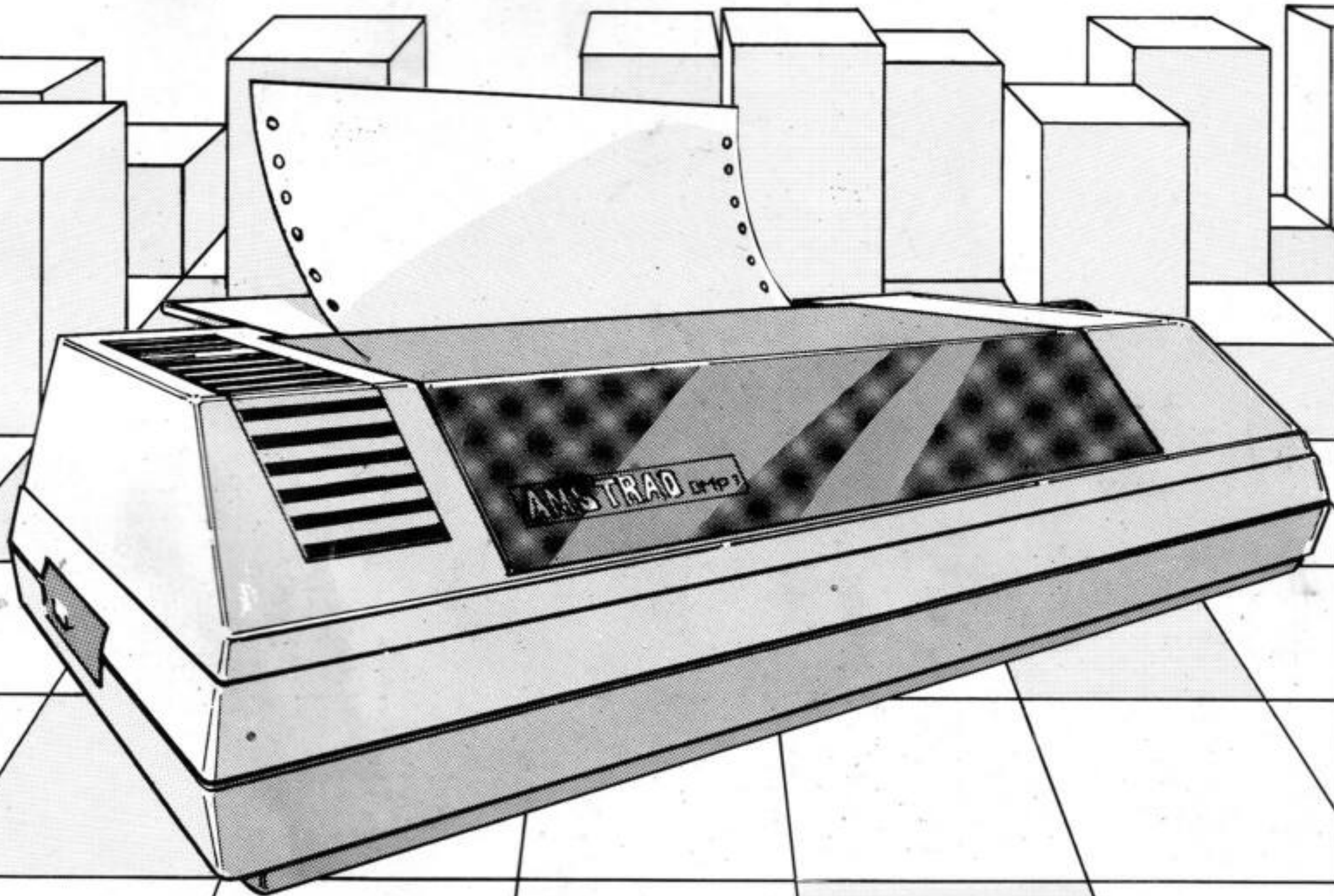

CONTENTS

SETTING UP THE DMP 1	1
Connecting the Mains Lead	1
Preparation	2
Fitting the Ribbon	3
Removing the Ribbon	4
Connecting the Printer to the Computer	5
Loading the Paper	6
Setting the Head Position	8
USING THE DMP 1	9
Switching on	9
Operation	9
Testing	9
WIDTH command	10
Formatting	11
TECHNICAL INFORMATION FOR THE USER	12
PRINT CONTROL FUNCTIONS	12
Function Code Table	12
Function Code Explanation	13
PROGRAM EXAMPLES	16
LINE FEED SPACING	17
AUTOMATIC PRINTING	18
SELF TEST PRINTING	18
DIP SWITCH SELECTION	18
CHARACTER CODE TABLE	19
INTERFACE	20
Connections	20
Input/Output Signals	21
Electrical Characteristics	22
Timing	23
TROUBLESHOOTING GUIDE	24
TECHNICAL SPECIFICATION	25
IMPORTANT NOTES	26

SETTING UP THE DMP 1

Connecting the Mains Lead

The Mains Lead is fitted at the rear of the unit. Fit a proper Mains Plug to the Mains Lead. If a 13 Amp (BS1363) Plug is used, a 3 Amp Fuse must be fitted. The 13 Amp Fuse supplied in a new Plug must NOT be used. If any other type of Plug is used, a 5 Amp Fuse must be fitted either in the Plug or Adaptor or at the Distribution Board.

WARNING: THIS APPARATUS MUST BE EARTHED

IMPORTANT: The wires in this Mains Lead are coloured in accordance with the following code:—

Green-and-yellow	:	Earth
Blue	:	Neutral
Brown	:	Live

As the colours of the wires in the Mains Lead of this apparatus may not correspond with the coloured markings identifying the terminals in your Plug, proceed as follows:

The wire which is coloured Green-and-Yellow must be connected to the terminal in the Plug which is marked either with the letter 'E' or by the safety earth symbol  or coloured Green or Green-and-Yellow.

The wire which is coloured Blue must be connected to the terminal which is marked with the letter 'N' or coloured Black.

The wire which is coloured Brown must be connected to the terminal which is marked with the letter 'L' or coloured Red.

Disconnect the Mains Plug from the Supply Socket when not in use.

Never attempt to remove any screws, or open the case of the DMP1. Always obey the warning on the Rating Label which is located on the back panel of the DMP1:—

WARNING LIVE PARTS INSIDE. DO NOT REMOVE ANY SCREWS.

Preparation

1. Remove the adhesive tape on top of the DMP1, and open the tinted-perspex printer cover by lifting the rear edge forward.
2. Inside the printer mechanism, you will see a corrugated black plastic tube with a label attached.

This tube must be removed before connecting the DMP1 to the Mains Supply. To remove the tube, simply pull on the attached label.

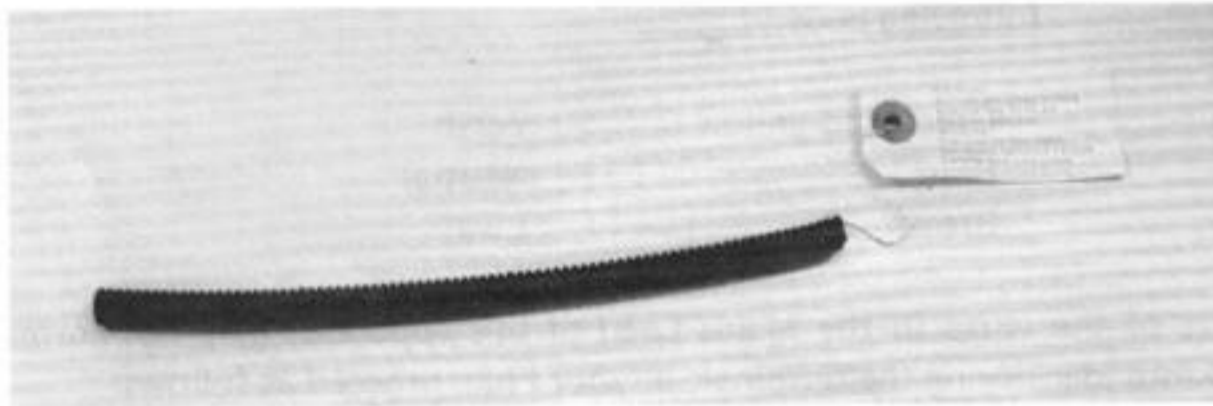

Figure 1

3. On the left hand inside wall of the printer mechanism, you will find a metal lever located in a curved adjustment slot. This is the Head Adjustment Lever, and should be pressed in and moved fully towards the front of the DMP1.

Fitting the Ribbon

The ribbon should be fitted when there is no paper loaded into the printer.

The ribbon for the DMP1 comes in the form of a cassette, which you will find in its own small box packed within the main carton.

1. Remove the ribbon cassette from its polythene bag, and gently turn the knob on the top of the cassette in the direction indicated by the arrow to straighten the ribbon at the front of the cassette (see Figure 2).

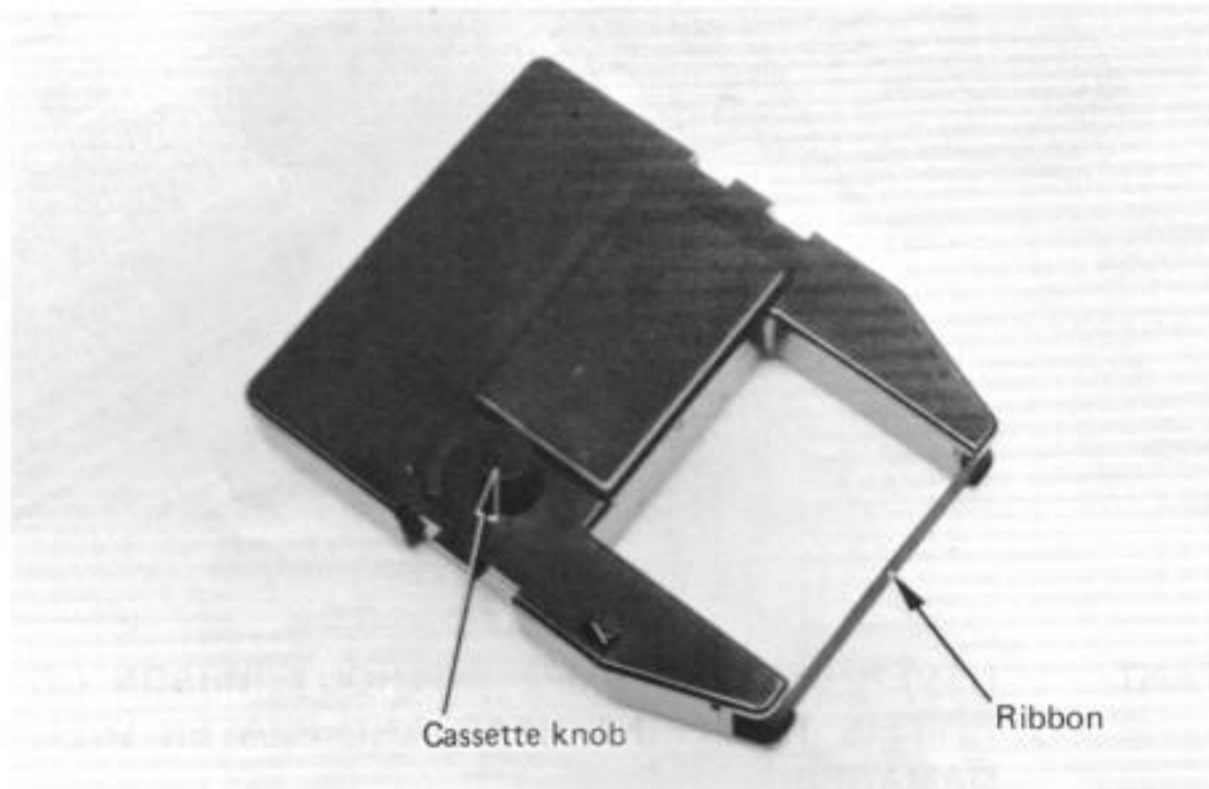

Figure 2

2. Place the cassette so that the ribbon slides in between the print head and the platen (see Figure 3), then place the cassette down into position between the latching-clips either side of the cassette.

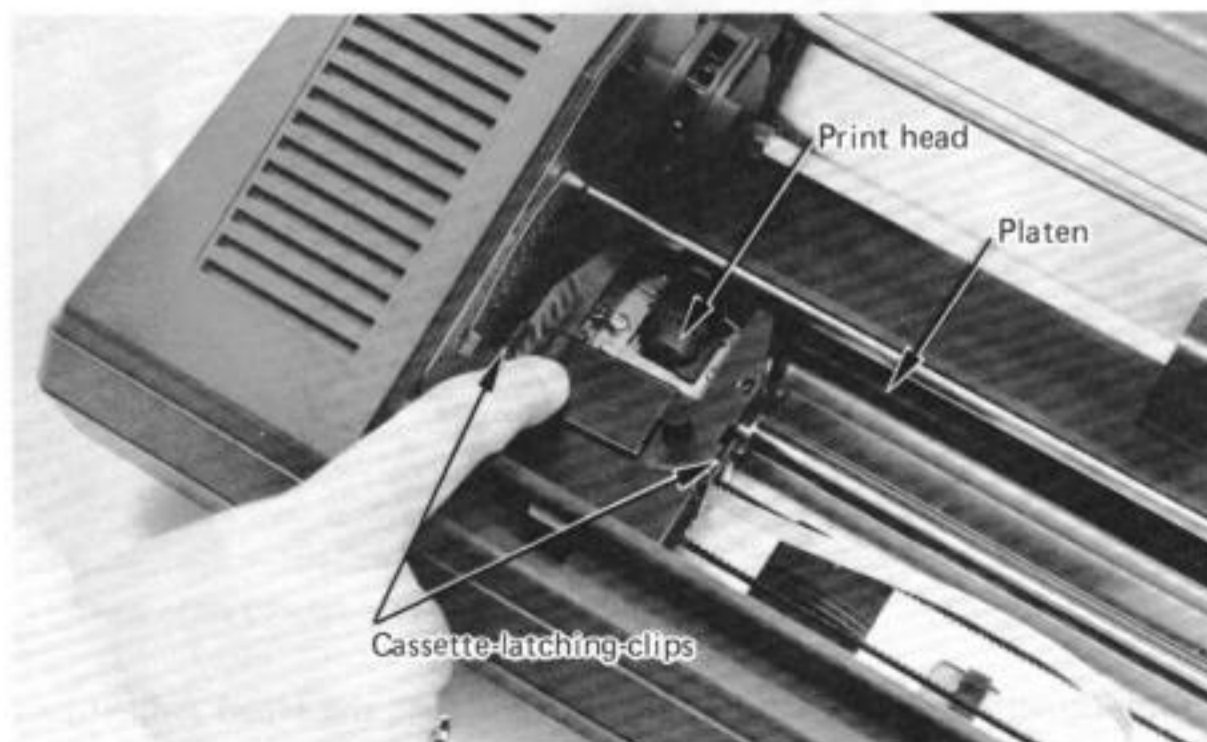

Figure 3

The left side of the Cassette should be located down into its latching-clip. The right side of the cassette however, may still be raised above its locating position; if so, carry out instruction 3 as follows:

3. While turning the cassette knob in the direction indicated by the arrow, press downwards on the right hand side of the cassette until it locates down into the right hand latching-clip (see Figure 4).



Figure 4

IMPORTANT – NEVER USE THE DMP1 WITHOUT RIBBON OR PAPER FITTED. THE PRINT HEAD AND PLATEN WILL BE DAMAGED.

Removing the Ribbon

To remove the ribbon cassette, slide the Head Adjustment Lever fully towards the front of the DMP1 as described in 'Preparation'-Part 3, then move the right hand cassette-latching-clip, gently outwards, and lift the cassette out of the DMP1 (see Figure 5).



Figure 5

To fit a new replacement ribbon cassette, ensure first that the Head Adjustment Lever is fully towards the front of the printer, then simply follow the previous instructions for fitting the Ribbon.

Connecting the Printer to the Computer

Having carried out the procedures described in the previous sections, the printer may now be connected to the CPC464 computer by following the instructions below:

1. Check that both the DMP1 printer and the CPC464 computer are switched off.
2. The connector at the rear of the DMP1 is a Centronics-style socket, (Figure 6a) which you should find easily distinguishable from the PCB edge connector used at the rear of the CPC464 (Figure 6b).
3. The DMP1 is supplied complete with a cable (Figure 6c) that allows direct connection to the PRINTER connector at the rear of the CPC464. Figure 6 also shows how this cable is to be fitted. Firm pressure will be required to ensure that a good connection is made.
4. After connecting the Centronics-style plug into the rear socket of the DMP1, lock the plug into position by pressing the metal clips either side of the socket into the cut-outs at the side of the plug.

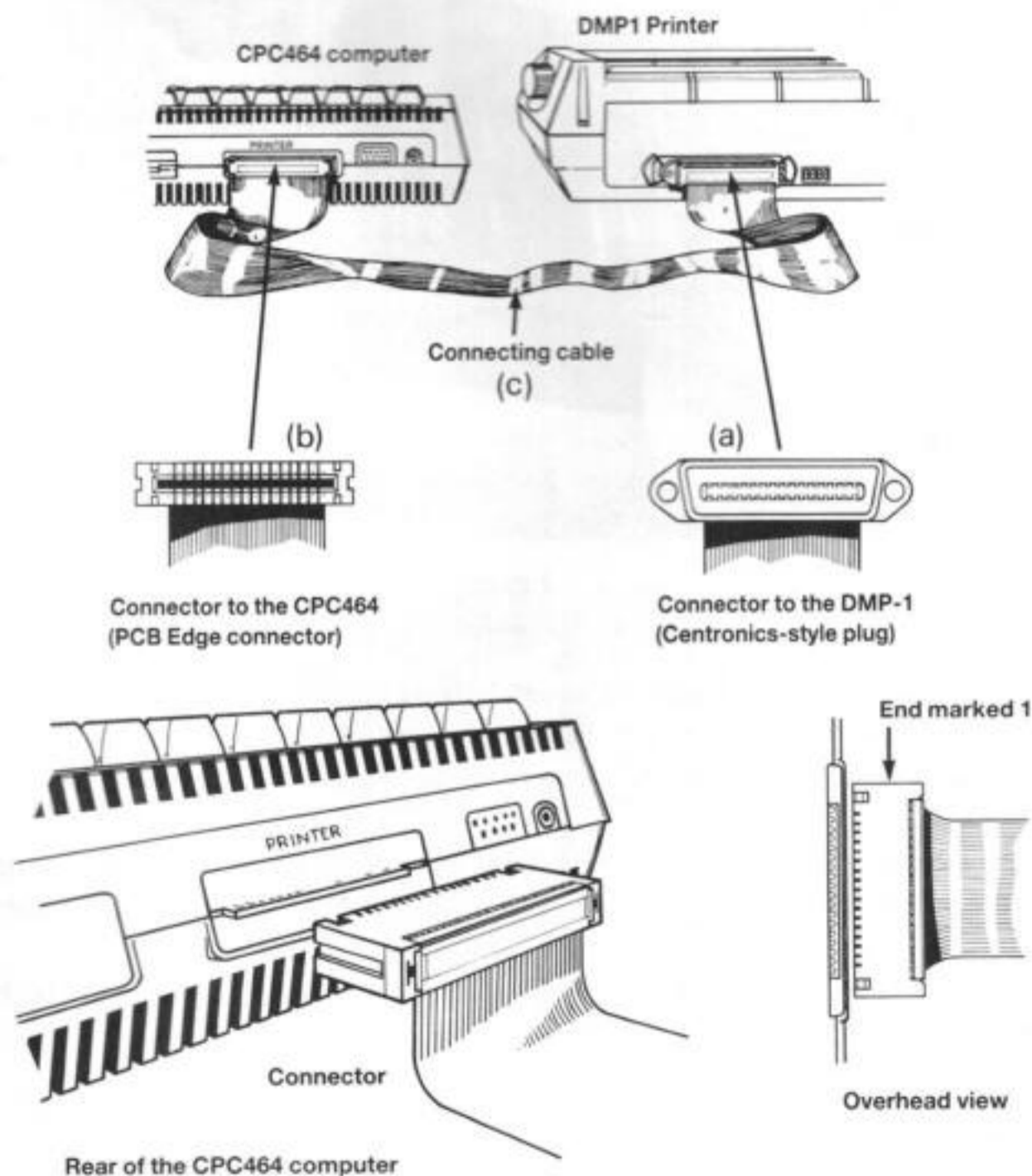

Figure 6

Loading the Paper

The tinted-perspex paper shelf will be found packed within the main carton. Fit the paper shelf to the back of the DMP1 as follows:

1. Hold the paper shelf vertically with the flat face towards you and the circular hinge-holes facing downwards.
2. Lower the paper shelf so that the hinge-holes locate over the hinge-pegs, which you will find just in front of the red WARNING label.
The paper shelf may now be hinged to an up or down position. To load the paper, keep the paper shelf up (see Figure 7).

NOTE — THE DMP1 WILL ONLY ACCEPT TRACTOR-FEED TYPE PAPER.

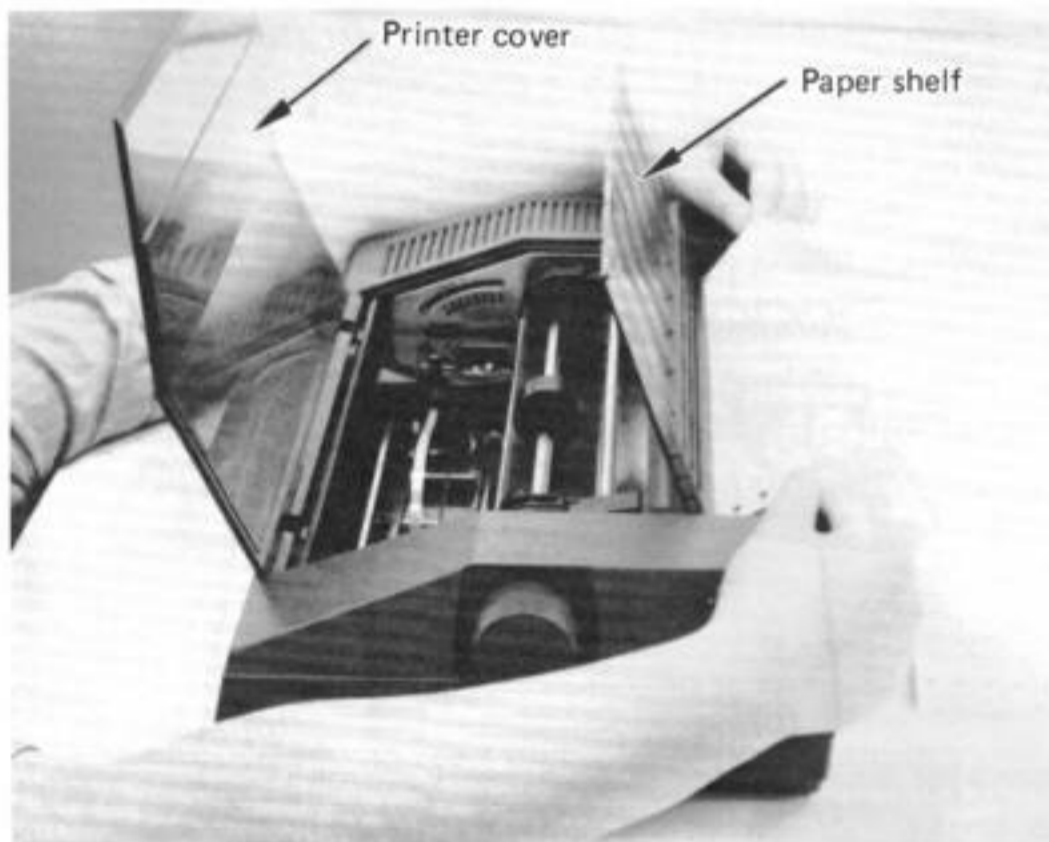

Figure 7

3. Ensuring that the Head Adjustment Lever is fully towards the front of the printer, feed the paper into the rear of the printer, behind the paper shelf. Keep feeding-in the paper until you are able to pull it through, when it emerges inside the printer mechanism.
4. On either side of the central rubber roller, you will see an enclosed plastic cogged-wheel. These are called 'tractors' and they transport the paper through the printer mechanism.

Slide either of the tractors sideways if necessary until its cogs line up with the holes in the side of the paper.

5. Open the tractor-covers by flipping the tops outwards (see Figure 8).

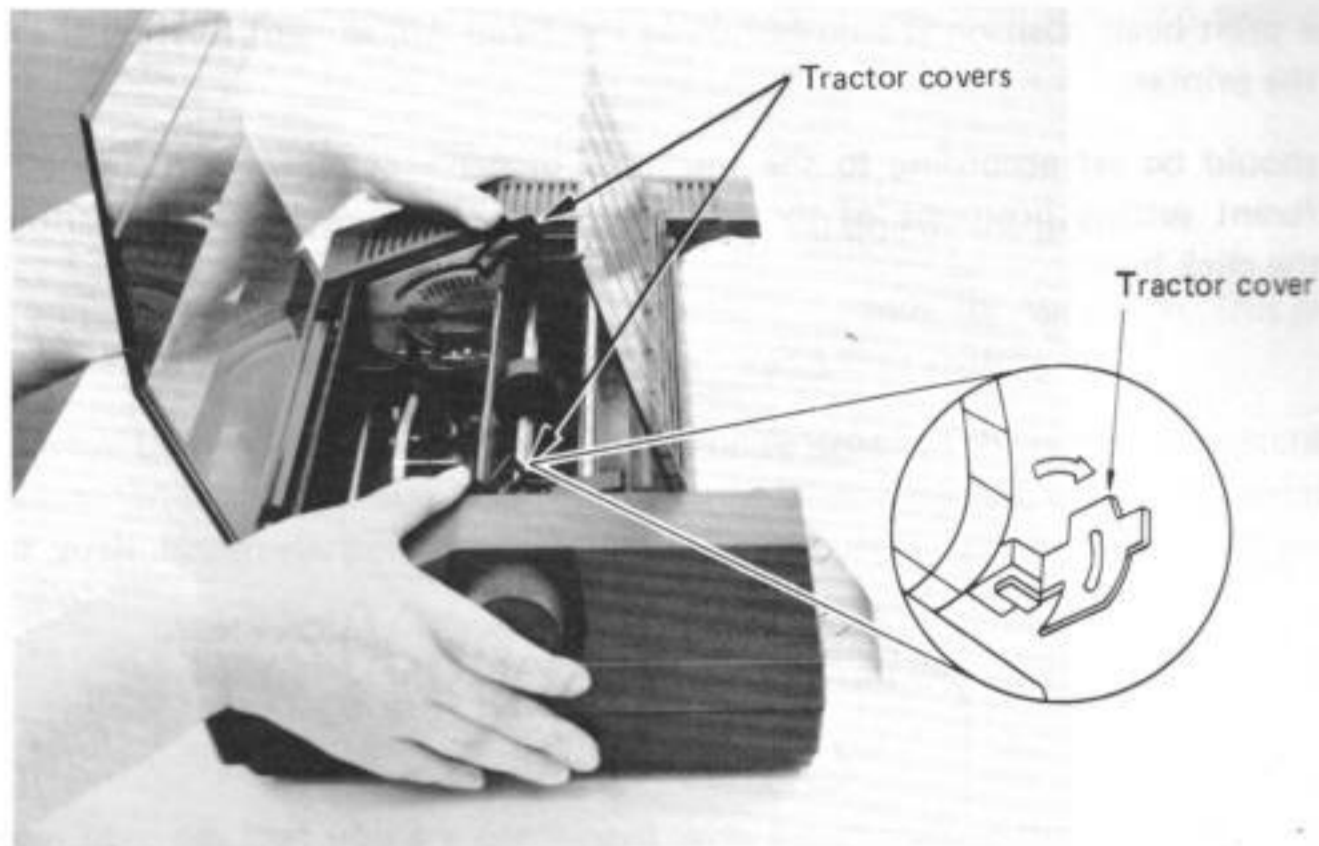

Figure 8

6. Position the paper so that its holes are aligned over the cogs, then close the tractor-covers over the paper.

ENSURE THAT THE PAPER IS POSITIONED SO THAT THE BEGINNING OF THE PAPER ON THE LEFT HAND SIDE, IS BEHIND THE PRINT HEAD.

The paper shelf at the back of the printer can now be laid flat (see Figure 9).



Figure 9

The paper feed knob on the right hand side of the DMP1 may now be used to manually advance the paper.

Setting the Head Position

The print head position is adjusted using the Head Adjustment lever on the left hand inside wall of the printer.

It should be set according to the thickness of paper being used. Figure 10 below shows the 8 different setting positions of the lever which are indicated by the position of the lever foot in the click holes.

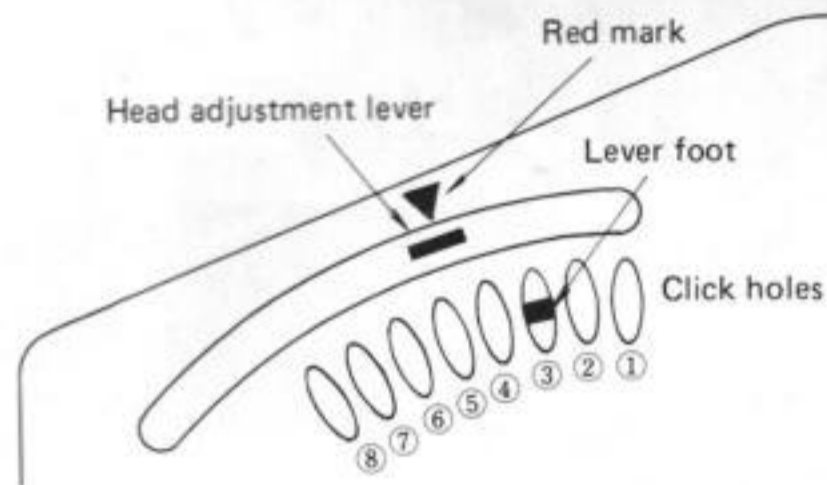

Figure 10

The settings graduate from position ① for very thin paper, to position ⑧ for thicker paper. Position ③, indicated by a red arrow above the Head Adjustment slot, is suitable for general purpose computer paper, including Amsoft Printer Paper.

During insertion or removal of the paper or ribbon cassette, the Head Adjustment lever should be set fully towards the front of the printer (past position ⑧).

The tinted-perspex printer cover can now be lowered backwards to its closed position, ready for operation. Keeping the cover closed will help reduce noise, and keep the printer mechanism dust free.

USING THE DMP 1

Switching On

After each of the setting up operations described in the previous sections has been carried out, the DMP1 is ready for use.

Switch on the computer and monitoring equipment.

Switch on the DMP1 using the ON/OFF switch on the left hand side of the printer.

The printer head will move for a few seconds then come to rest, ready for operation. This process is called 'initialization' and will always occur when the printer is first switched on.

The POWER indicator LED on top of the DMP1 will illuminate when the printer is switched on. If the POWER indicator flashes on and off, an error has been detected, such as incorrect initialisation. Under such circumstances, switch the DMP1 off, wait approximately 10 seconds, then switch on again.

Operation

It is assumed from here on, that you are conversant with programming the CPC464 computer, and have carefully read the main User Instruction book, particularly its references to using a printer, which will be found in Chapter 7 page 2.

Testing

To check the operation of the printer, fully reset the computer, and type in the following program:

```
10 FOR n=32 TO 126
20 PRINT #8,CHR$(n),n
30 NEXT
```

The above program will tell the DMP1 to print out each of the ASCII display characters, followed by its corresponding reference number (as shown in Appendix III of the CPC464 User Instruction book).

The reason that the characters were printed out by the DMP1 instead of being displayed on the monitor screen, was the use of the expression #8.

is a stream director. It tells the computer to which stream the text must be directed. Streams 0 to 7, (#0 to #7) are monitor display streams (or windows), with #0 being the default stream (directed to if no stream is specified). It can be seen therefore that #8 is the printer stream.

To demonstrate this aspect of operation, edit line 20 as follows, and run the program again:

```
20 PRINT #0,CHR$(n),n
```

You will note that the same text has now been directed to the monitor screen. Similarly, listing a program, which is normally performed by typing in:

```
LIST
```

can be directed to the printer, by typing in:

```
LIST #8
```

WIDTH Command

Using the WIDTH command enables you to select the number of characters per line to be printed by the DMP1.

This command may also be used if the DMP1 is to be operated with narrow paper.

If no WIDTH command is specified, the computer will assume a WIDTH of 132 (default). It should be noted therefore, that as the DMP1 will only print a maximum of 80 characters per line, the remaining 52 characters will be 'wrapped' onto the following line.

To demonstrate this aspect of operation, fully reset the computer and type in the following program:

```
20 FOR n=1 TO 132
30 PRINT #8,"x";
40 NEXT
50 PRINT #8
```

Notice how the last 52 characters are 'wrapped' onto the second line.

Now type in, then run:

```
10 WIDTH 44
```

The computer has now been instructed to set the number of characters per line to **44**. Run the program again using the following WIDTH commands:

```
10 WIDTH 12
```

then try:

```
10 WIDTH 4
```

Note that the **MODE** in which the computer is operating (ie. 20, 40 or 80 column) bears no relationship with the size or number of characters per line on the printer.

When using the DMP1 for dot graphic printing, or for any other application where unlimited line 'wrapping' is required, this can be achieved by typing in:

```
WIDTH 255
```

A WIDTH command can be entered into the computer in direct or program mode.

Formatting

Formatting the display on the monitor screen, using the ZONE, PRINT TAB, PRINT SPC, and PRINT USING commands, can be similarly applied to printer operation; See Chapter 3 pages 6 and 7, and Chapter 8 pages 53, 54 and 55 of the CPC464 User Instruction book.

TECHNICAL INFORMATION FOR THE USER

PRINT CONTROL FUNCTIONS

Function Code Table

NO.	SYMBOL	CODE		FUNCTION
		HEX	DEC	
1	NL	0A	10	Both a line feed and carriage return are executed after printing.
2	CR	0D	13	Both a line feed and carriage return, or carriage return only (switch selectable) are executed after printing.
3	DC4	14	20	Carriage return is executed after printing.
4	SO	0E	14	Double width character specification.
5	SI	0F	15	Standard character specification.
6	DLE	10	16	Print position specification in character units.
7	ESC DLE	1B 10	27 16	Print position specification in dot units.
8	ESC K	1B 4B	27 75	Graphics printing specification.
9	FS	1C	28	Specifies the repetition of one byte of graphic print data.

Function Code Explanation

1.

NL

 (0A) Hex (10) Decimal

Print command. Input of this code causes the data in the printer's buffer to be printed then a line feed and carriage return executed. If there is no print data in the buffer, a line feed alone is executed.

2.

CR

 (0D) Hex (13) Decimal

Print command. Input of this code causes the data in the printer's buffer to be printed and brings the print head back to the home position. The execution of a line feed after printing is determined by the setting of dip switch number 4. The print head does not move when there is no print data in the buffer.

3.

DC4

 (14) Hex (20) Decimal

Print command. This code causes the data in the printer's buffer to be printed and a carriage return executed without a line feed.

In cases where there is no print data stored in the buffer, the print head does not move.

4.

SO

 (0E) Hex (14) Decimal

The characters that follow this code are printed in the double width format.

5.

SI

 (0F) Hex (15) Decimal

Input of this code clears the double width print mode and returns to the standard character print mode. The latter mode is selected after applying power.

6.

DLE	n_H	n_L
-----	-------	-------

 (10) $n_H n_L$ Hex
(16) $n_H n_L$ Decimal

This is the command to specify the print position in character units. $n_H n_L$ is ASCII code for a two-digit decimal number where $0 \leq n_H n_L \leq 79$. When $n_H n_L \geq 80$, the three-byte of

DLE	n_H	n_L
-----	-------	-------

 is ignored.

Example: If you wish to print "A" at the 10th column, input the four bytes of

10	30	39	41
----	----	----	----

 hex.

7.

ESC	DLE	n_H	n_L
-----	-----	-------	-------

 (1B) (10) $n_H n_L$ Hex
(27) (16) $n_H n_L$ Decimal

This designates the print position in dot units. $n_H n_L$ is 2-byte binary data used to indicate the print position away from the home position and is treated as a single 9 bit binary data inside the printer.

Example:

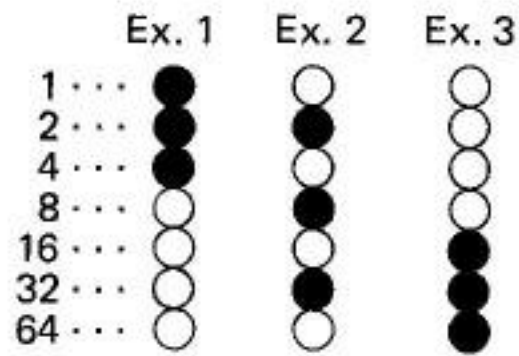

The graphics data for ex. 1 is
 $(1 + 2 + 4) = 7$

The graphics data for ex. 2 is
 $(2 + 8 + 32) = 42$

The graphics data for ex. 3 is
 $(16 + 32 + 64) = 112$

9.

FS	n	GD
----	---	----

(1C) n GD Hex

(28) n GD Decimal

The command specifies the repeated printing of a graphic data. n is the binary number of repetition and GD is one byte data for graphics. n is in the range 0 ~ 127 with 0 meaning that the graphics data is to be repeated 128 times.

0	0	0	1	1	1	0	0 FS code
x	R ₇	R ₆	R ₅	R ₄	R ₃	R ₂	R ₁ Number of repetitions
x	P ₇	P ₆	P ₅	P ₄	P ₃	P ₂	P ₁ Graphic data to be repeated

(x = don't care)

PROGRAM EXAMPLES

1. **NL**

```
10 PRINT #8,"LINE ONE"+CHR$(10);
20 PRINT #8,"LINE TWO"
30 END
```

```
LINE ONE
LINE TWO
```

2. **DC4**

```
10 PRINT #8,"LINE ONE"+CHR$(20);
20 PRINT #8,"LINE TWO"
30 END
```

```
LINE ONE
LINE TWO
```

3. **SO**, **SI**

```
10 PRINT #8,CHR$(14)+"DOUBLE"
20 PRINT #8,"WIDTH"
30 PRINT #8,CHR$(15)+"STANDARD"
40 END
```

```
DOUBLE
WIDTH
STANDARD
```

4. **DLE**

```
10 PRINT #8,CHR$(16)+"20";
20 PRINT #8,"BEAUTIFUL LADY, SALLY"
30 END
```

```
BEAUTIFUL LADY, SALLY
```

5. **ESC** **DLE**

```
10 PRINT #8,CHR$(27)+CHR$(16)+CHR$(1)+CHR$(122);
20 PRINT #8,"Attractive Gill"
30 END
```

```
Attractive Gill
```

6. ESC K

```

10 PRINT #8,CHR$(27);CHR$(75);CHR$(0);CHR$(42);
20 FOR m=1 TO 3
30 RESTORE 90
40 FOR i=1 TO 14
50 READ a
60 PRINT #8,CHR$(a);
70 NEXT i
80 NEXT m
90 DATA 8,20,34,65,34,20,8,8,20,34,65,34,20,8
100 PRINT #8,CHR$(15)
110 END

```

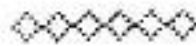
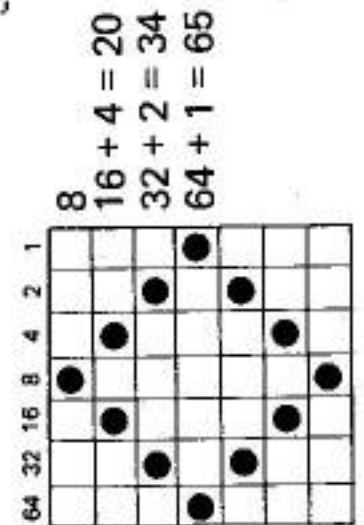

7. FS

```

10 PRINT #8,CHR$(28)+CHR$(127)+CHR$(875)
20 PRINT #8,CHR$(15)
30 END

```



8. Intermixed

```

10 PRINT #8,CHR$(16)+"10";
20 PRINT #8,CHR$(27);CHR$(75);CHR$(0);CHR$(7);
30 FOR i=1 TO 7
40 READ a
50 PRINT #8,CHR$(a);
60 NEXT i
70 DATA 8,20,34,65,34,20,8
80 PRINT #8,CHR$(14)+" LOVELY ";
90 PRINT #8,CHR$(15)+"LADY"
100 END

```

◇ LOVELY LADY

LINE FEED SPACING

When operating in the character mode, line feeds are generated at 1/6" pitch.

When operating in the graphics mode, selected by using codes ESC K n_H n_L or FS n GD, line feeds are set to 1/9" pitch.

Having returned to the character mode after graphics printing, it will be necessary to reset the line feed pitch to 1/6" by using codes SI or SO.

- Standard and double width character modes 6 lines/inch
- Graphics mode 9 lines/inch

AUTOMATIC PRINTING

Printing takes place automatically when either of the two conditions listed below occurs.

- (1) During data input, the buffer becomes full and where the next inputting data is print data.
- (2) Where one print data of character cannot be printed within the 480th dot column in the character printing mode, the input data prior to it is printed automatically, the remainder being printed from the first column of the next line.

In cases where either of the above two conditions occur, the last input data will remain in the buffer.

SELF TEST PRINTING

Connecting the TEST line of 35 pin to the GND line of pin 15 on the input connector starts self test printing which continues until disconnected.

DIP SWITCH SELECTION

You will find the DIP switches on the rear panel of the DMP1, next to the Centronics-style connector socket.

You will receive the DMP1 set by the factory for U.K. language characters (see table below). This will enable you to use programs which incorporate the £ sign, such as home budgeting and accounting programs.

You should note however, that when listing programs incorporating the # sign, it will be printed as £.

If at any time you wish to print # signs, simply set DIP switch No. 3 off (down). It should then be noted, that under this condition, £ signs will be printed as #.

Setting DIP switch No. 4 on (up), will result in double line spacing by the printer, as opposed to the normal single line spacing.

DIP switches 1, 2 and 3 are used to select eight different language characters as follows.

Code (HEX) Country	23	24	40	5B	5C	5D	5E	60	7B	7C	7D	7E		SW1	SW2	SW3
U.S.A.	#	\$	@	[\]	^	'	{		}	~		OFF	OFF	OFF
U.K.	£	\$	@	[\]	^	'	{		}	~		OFF	OFF	ON
GERMANY	#	\$	§	Ä	Ö	Ü	^	'	ä	ö	ü	β		OFF	ON	OFF
SWEDEN	#	☉	É	Ä	Ö	Å	Ü	é	ä	ö	å	ü		OFF	ON	ON
FRANCE	#	\$	à	°	ç	§	^	'	é	ù	è	''		ON	OFF	OFF
DENMARK	#	\$	@	Æ	Φ	Å	^	'	æ	φ	å	~		ON	OFF	ON
ITALY	#	\$	@	°	\	é	^	'	à	ò	è	ì		ON	ON	OFF
SPAIN	Pt	\$	@	ì	Ñ	¿	^	'	..	ñ	}	~		ON	ON	ON

DIP switch 4 is for changing **CR** code meaning.

SW4

ON **CR** is identical to **NL**
OFF **CR** is identical to **DC4**

CHARACTER CODE TABLE

!"£\$%&'() * + , - . / 0 1 2 3 4 5 6 7 8 9 : ; < = > ? @ A B C D E F G H I J K L M N O P Q R S T U V W X Y Z [\] ^ _ ` a b c d e f g h i j k l m n o p q r s t u v w x y z { | } ~

Upper Bit Lower Bit	Hex.	0	1	2	3	4	5	6	7
Hex.	Binary	0000	0001	0010	0011	0100	0101	0110	0111
0	0000	0 DLE	16 SP	32 0	48 @	64 P	80 ⊙	96 p	112 q
1	0001	1 !	17 1	33 A	49 Q	65 a	81 r	97 b	113 r
2	0010	2 "	18 !	34 B	50 R	66 b	82 c	98 s	114 s
3	0011	3 "	19 "	35 ⊕	51 C	67 S	83 c	99 t	115 t
4	0100	4 DC4	20 ⊕	36 \$	52 4	68 D	84 T	100 d	116 t
5	0101	5 %	21 %	37 %	53 5	69 E	85 U	101 e	117 u
6	0110	6 &	22 &	38 &	54 6	70 F	86 V	102 f	118 v
7	0111	7 '	23 '	39 '	55 7	71 G	87 W	103 g	119 w
8	1000	8 {	24 {	40 {	56 8	72 H	88 X	104 h	120 x
9	1001	9 }	25 }	41 }	57 9	73 I	89 Y	105 i	121 y
A	1010	10 NL	26 *	42 *	58 :	74 J	90 Z	106 j	122 z
B	1011	11 ESC	27 +	43 +	59 ;	75 K	91 ⊙	107 k	123 ⊙
C	1100	12 FS	28 ,	44 ,	60 <	76 L	92 ⊙	108 l	124 ⊙
D	1101	13 CR	29 -	45 -	61 =	77 M	93 ⊙	109 m	125 ⊙
E	1110	14 SO	30 .	46 .	62 >	78 N	94 ⊙	110 n	126 ⊙
F	1111	15 SI	31 /	47 /	63 ?	79 O	95 -	111 o	127 SP

Circled characters are selected by the positions of DIP switches 1, 2 and 3.

INTERFACE

Connections

Input connector on the printer and the signal pinout.

DDK 36 pin BAIL LOCK TYPE
(57 LE-40360-270B-D3)

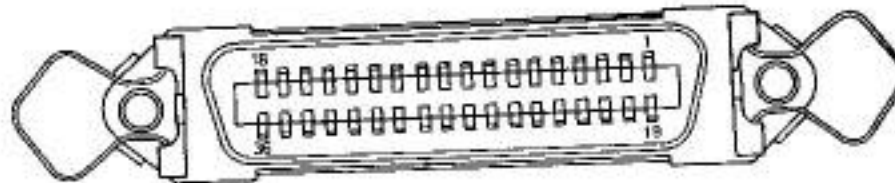

PIN	SIGNAL	PIN	SIGNAL
1	<u>STROBE</u>	19	TWISTED PAIR GND (PAIR WITH 1 PIN)
2	DATA 1	20	TWISTED PAIR GND (PAIR WITH 2 PIN)
3	DATA 2	21	TWISTED PAIR GND (PAIR WITH 3 PIN)
4	DATA 3	22	TWISTED PAIR GND (PAIR WITH 4 PIN)
5	DATA 4	23	TWISTED APRI GND (PAIR WITH 5 PIN)
6	DATA 5	24	TWISTED PAIR GND (PAIR WITH 6 PIN)
7	DATA 6	25	TWISTED PAIR GND (PAIR WITH 7 PIN)
8	DATA 7	26	TWISTED PAIR GND (PAIR WITH 8 PIN)
9	DO NOT USE	27	TWISTED PAIR GND (PAIR WITH 9 PIN)
10	<u>ACK</u>	28	TWISTED PAIR GND (PAIR WITH 10 PIN)
11	BUSY	29	TWISTED PAIR GND (PAIR WITH 11 PIN)
12	LOW	30	GND
13	NC	31	<u>INITIAL</u> (PAIR WITH 14 PIN)
14	GND	32	<u>ERROR</u> (PAIR WITH 15 PIN)
15	GND	33	GND
16	GND	34	NC
17	CHASSIS GND	35	<u>TEST</u> (PAIR WITH 16 PIN)
18	+5V 80mA Max.	36	NC

NOTE:

1. NC stands for no connection.
2. LOW is the LOW LEVEL output of 74LS04.

Signal cable length

Maximum length is two meters with the following signals forming twisted pairs with the GND.
STROBE, INITIAL, BUSY, ACK, ERROR

Input/Output Signals

a. Input signals to the Printer

- * DATA 1
DATA 2
DATA 3
DATA 4
DATA 5
DATA 6
DATA 7
DATA 8 } 7-bit data signals
Signal "HIGH" represents Logic "1".
- * $\overline{\text{STROBE}}$ The strobe signal is used to read in 8 bits of data. Data is read in when the signal goes "LOW".
- * $\overline{\text{INITIAL}}$ This signal is used to set the Printer to an initial state and is normally "HIGH". Bringing the line "LOW" and returning it "HIGH" starts the clearing action which sets the Printer to an initial state.
- * $\overline{\text{TEST}}$ This signal is used for self test printing which is executed by bringing the line "LOW".

b. Output signals from the Printer

- * BUSY This signal indicates the BUSY status of the Printer. When "HIGH" the Printer can not accept data.
- * $\overline{\text{ACK}}$ This signal is used to indicate that the Printer is awaiting data.

NOTE: The BUSY and $\overline{\text{ACK}}$ signals are always output when the Printer accepts data input.

- * $\overline{\text{ERROR}}$ A printer error condition causes this signal to go "LOW". When this happens, the internal control circuits stop. There are two ways to correct this situation:—
 - 1) Switch the Printer off, wait approximately ten seconds, then switch on again.
 - 2) Input the $\overline{\text{INITIAL}}$ signal.An $\overline{\text{ERROR}}$ occurs and the POWER LED flashes on and off if the dot timing becomes incorrect.

Electrical Characteristics

a. Signal levels

All input/output signals are TTL level.

"HIGH" level +2.4 ~ 5.0V
 "LOW" level +0.0 ~ 0.4V at the Printer input terminals

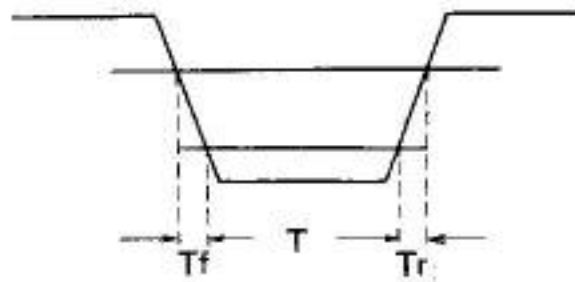

T_f and $T_r = 100$ ns or less
 $T =$ value shown on the timing chart

b. Input/output conditions

Input/output signals are pulled up with 10 k ohms.

* Input signals

The input load corresponds to one 74LS04

* Output signals

The output corresponds to a 74LS04. The recommended output load corresponds to one LSTTL load.

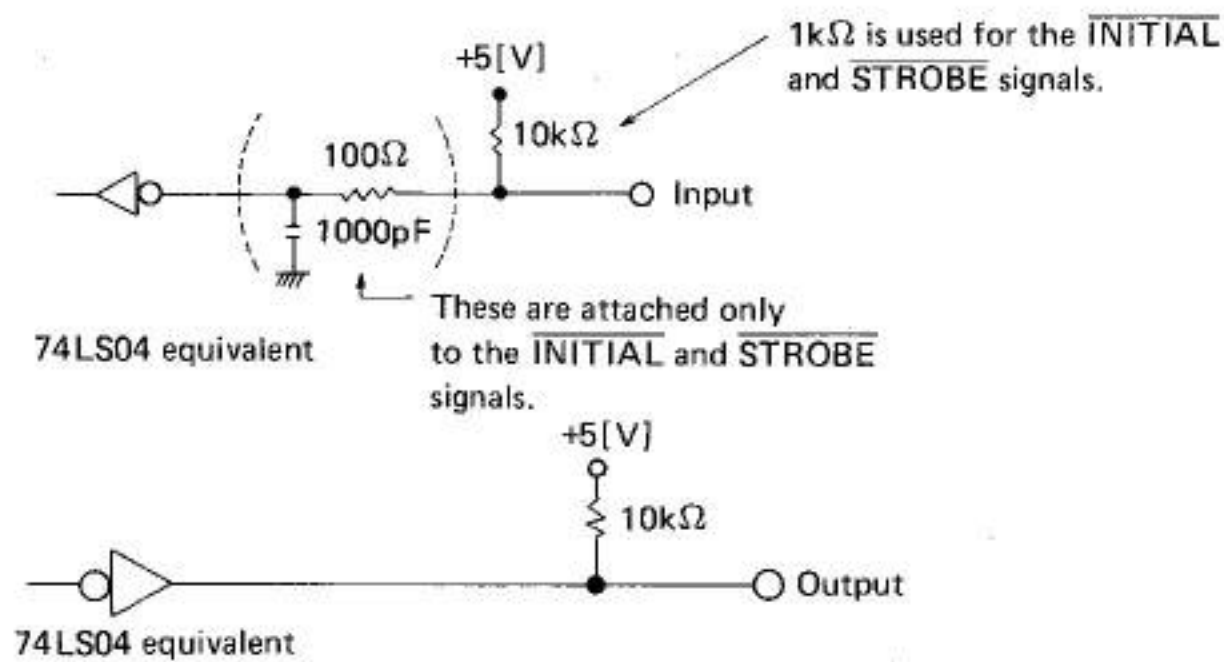

Timing

a. Data input

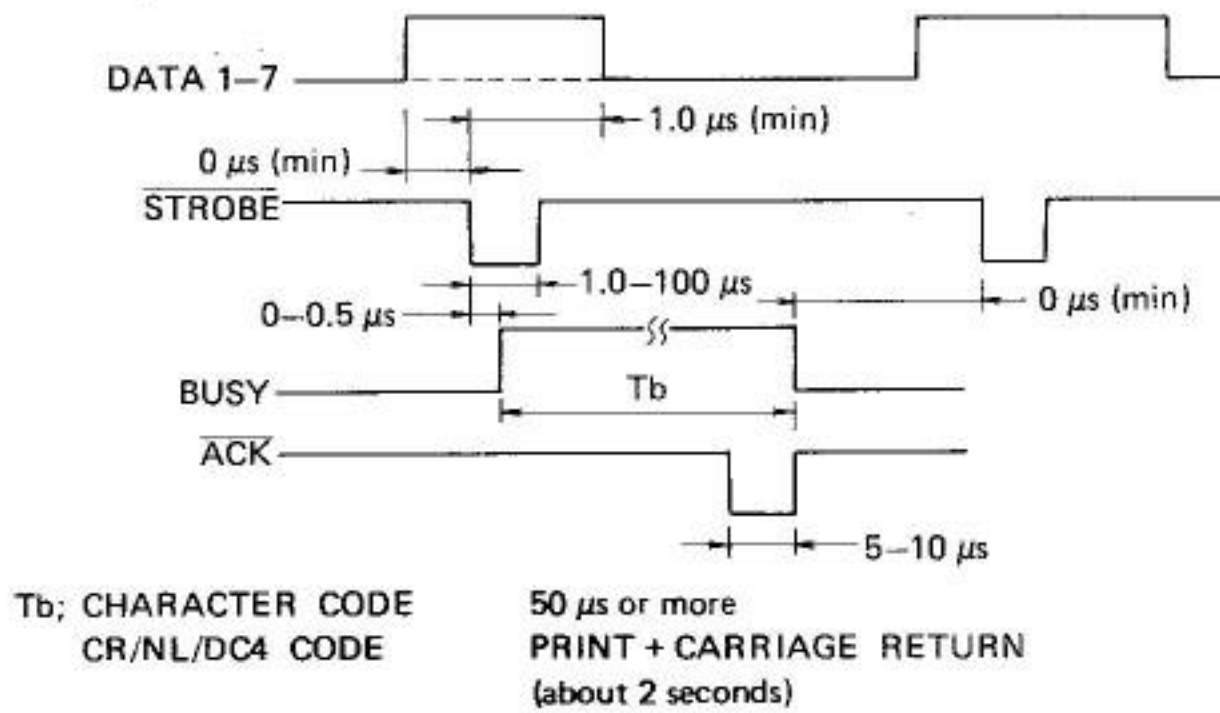

Reference: CR = (0, D), NL = (0, A), DC4 = (1, 4)

b. INITIAL signal input timing

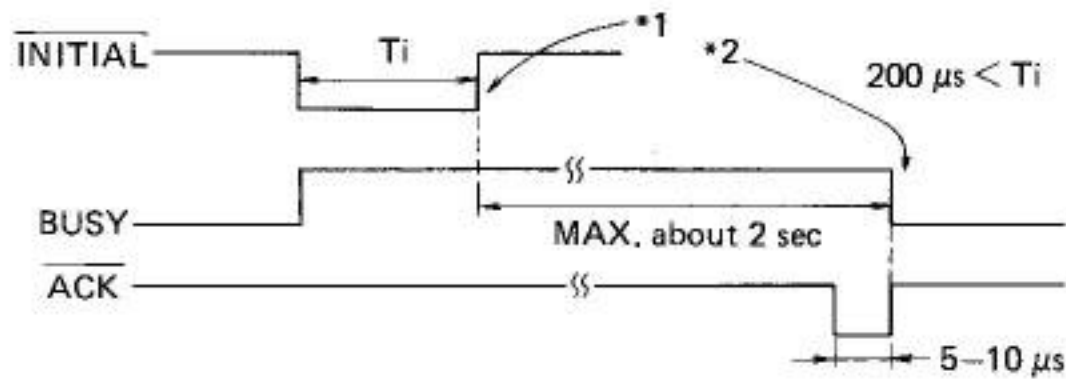

- *1 During T_i , the INITIAL line is "LOW" and the Printer is held in a reset state. The initialization sequence starts execution after the line goes "HIGH".
- *2 After the Printer finishes execution of the initialization sequence, the BUSY line goes "LOW".

TROUBLESHOOTING GUIDE

Use the table below to diagnose any problems that may occur. If you cannot solve the problem, try to establish which part of your system is not working correctly and consult your dealer.

PROBLEM	CAUSE AND REMEDY
The DMP1 does not print.	<ol style="list-style-type: none"> 1) Power is not getting to the DMP1 – Check the Mains Lead is connected and the ON/OFF switch is ON. 2) The Fuse in the Mains Plug may be blown – Replace it with a 3 Amp fuse.
The DMP1 does not print. The POWER LED is on.	<ol style="list-style-type: none"> 1) The connection to the computer is not correct – Check to make sure that the cable between the printer and the computer is correctly connected. 2) The ribbon cassette is not properly installed – Correctly install the ribbon according to the instructions in this book.
The DMP1 is operating correctly but the paper is not feeding properly.	<ol style="list-style-type: none"> 1) The paper is jammed in the printer – Remove the paper and reload it correctly.
The print is faint or smeared.	<ol style="list-style-type: none"> 1) The print head position is not correct – Set the head adjustment lever to match the type of paper being used. 2) The ribbon cassette is not properly installed – Correctly install the ribbon according to the instructions in this book. 3) The ink ribbon is worn – Replace the ribbon.
The POWER LED is flashing on and off.	<ol style="list-style-type: none"> 1) An error condition has occurred due to the detection of abnormal timing in a sensor – Switch power off, wait approx. 10 seconds, then switch on again.

TECHNICAL SPECIFICATION

Print method	:	Impact dot matrix
Print direction	:	Unidirectional (left to right)
Character matrix	:	5(width) x 7(height) + 1(space)
Characters	:	128 upper/lower case characters, numerals and symbols
Character code	:	7 bit ASCII
Dot spacing	:	1/60"(H) x 1/63"(V)
Character pitch	:	10 characters/inch
Character columns	:	80 columns-character mode 480 dot columns-graphics mode
Print speed	:	50 characters/second
Line feed spacing	:	6 lines/inch-character mode 9 lines/inch-graphics mode
Line feed speed	:	10 lines/sec (at 6 lines/inch) 15 lines/sec (at 9 lines/inch)
Graphics	:	Any combination of 7 dots in a vertical column
Multiple copies	:	Two including original (Thickness 0.15mm or less)
Paper width	:	4.5 to 10 inches acceptable (pin to pin 4 to 9.5 inches)
Power supply	:	220–240 V AC 50Hz
Dimensions	:	315(D) x 447(W) x 114(H)mm
Weight	:	4.8 kg

IMPORTANT NOTES

Always wait at least 10 seconds after switching the DMP1 off before switching it back on again. The initialization process may otherwise not be performed correctly.

The DMP1 should be used where the humidity is low, where there is little dust, and where it is not in direct sunlight.

The operating temperature range is 5°C to 40°C. Rapid temperature variations are to be avoided.

Be sure that the power is turned off to both the printer and the computer before connecting or disconnecting the signal cable from the computer.

Do not turn the power off while the DMP1 is printing.

Regardless of whether the power is ON or OFF, do not try to move or apply undue force to the print head.

Do not touch any of the moving parts of the DMP1 while it is in operation.

Do not operate the DMP1 without the ink ribbon cassette and paper properly installed. Failure to do so will cause damage to the print head and platen.

Disconnect the Mains Plug from the Supply Socket when not in use.

Never attempt to remove any screws, or open the case of the DMP1. Always obey the warning on the Rating Label which is located on the back panel of the DMP1:—

WARNING LIVE PARTS INSIDE. DO NOT REMOVE ANY SCREWS.

In keeping with our policy of continually improving our service and the technical quality of our products, we reserve the right to change component types, manufacturers, sources of supply or technical specification at any time.

AMSTRAD CONSUMER ELECTRONICS PLC
BRENIWOOD HOUSE
169 KING'S ROAD
BRENIWOOD
ESSEX CM14 4EF

Telephone: Brentwood (0277) 228888
Telex: 995417 Amsele G

If you have any enquiries relating to this unit, or to any of the AMSTRAD or AMSOFT range of computer products and peripherals, contact Amsoft Technical Enquiries on Brentwood (0277) 230222, during normal working hours.